

Model G8T-120 Rotary Gear Pump

Surex rotary gear pumps designed for foam extinguishing system. They are Self-Priming and can pump Multiple Viscosities of Foam or Water. This versatile design is suitable for Electric, PTO, Diesel/Gasoline Engine, Water Driven or Hydraulic drive motors.

Design Features:

- Timing Gears Synchronize the Two Pumping Rotors.
- Timing Gears Allow for DRY Running Without Damage.
- No Rotor Contact Allows for Pumping Foam or Water.
- Water Can Be Used for: Calibration, Testing and Training.

Technical Data:

Max Pressure: 2.0MPa | 20bar

Max Speed: 1800RPM

Viscosity : 9500cp max.[1]

Connection Diameter: DN100(114.3 O.D.)、4"

Connection Type: Groove、Thread、Flange

Approvals: FM

[1]Brookfield viscometer, spindle #4, speed 30rpm.

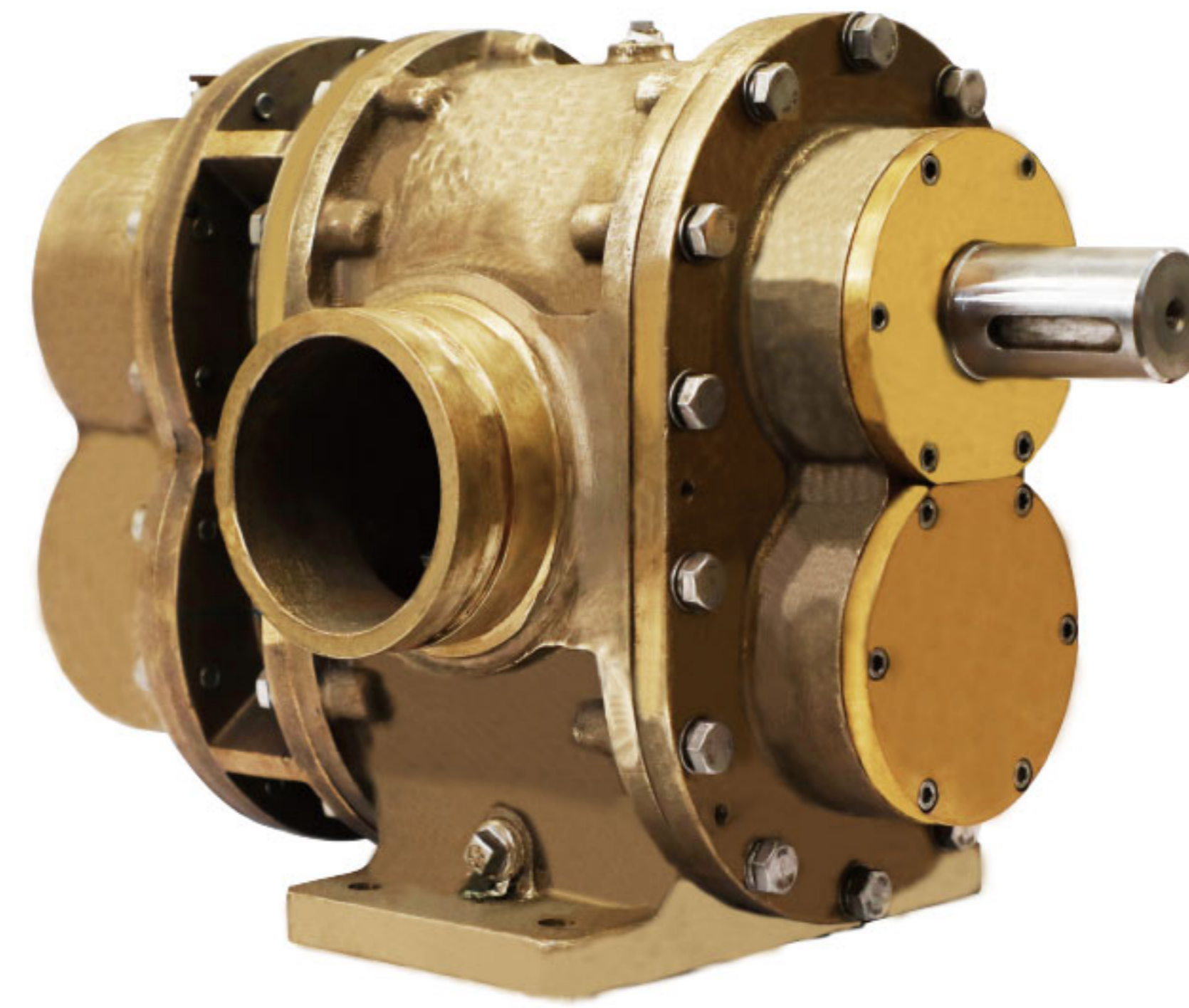

Materials :

Pump body: Red Brass, ASTM B584 C83600

Rotor: Stainless Steel 17-4PH

Red Brass, ASTM B584 C83600

Liners: Red Brass, ASTM B584 C83600

Front Cover: Red Brass, ASTM B584 C83600

Back Cover: Red Brass ASTM B584 C83600

Timing Gear: Alloy Steel 20CrMnTi (ASTM A29M)

Lip Seal : FPM

Performance -Water

Foam Pump	1000rpm			1200rpm			1500rpm			1800rpm			
	Pressure	Flow	Power	Torque	Flow	Power	Torque	Flow	Power	Torque	Flow	Power	Torque
	bar	L/min	kw	N.m	L/min	kw	N.m	L/min	kw	N.m	L/min	kw	N.m
	5.0	572	9	82	707	12	92	912	16	102	1088	22	116
	6.9	552	11	105	686	14	113	892	19	123	1068	26	136
	10.3	520	15	143	655	19	149	864	25	162	1040	33	173
	13.8	496	19	181	632	23	186	843	32	202	1019	40	211
	17.2	478	23	218	616	28	225	827	38	242	1004	47	250
	20.0	469	26	248	608	32	258	818	43	274	997	53	283

Dimensions

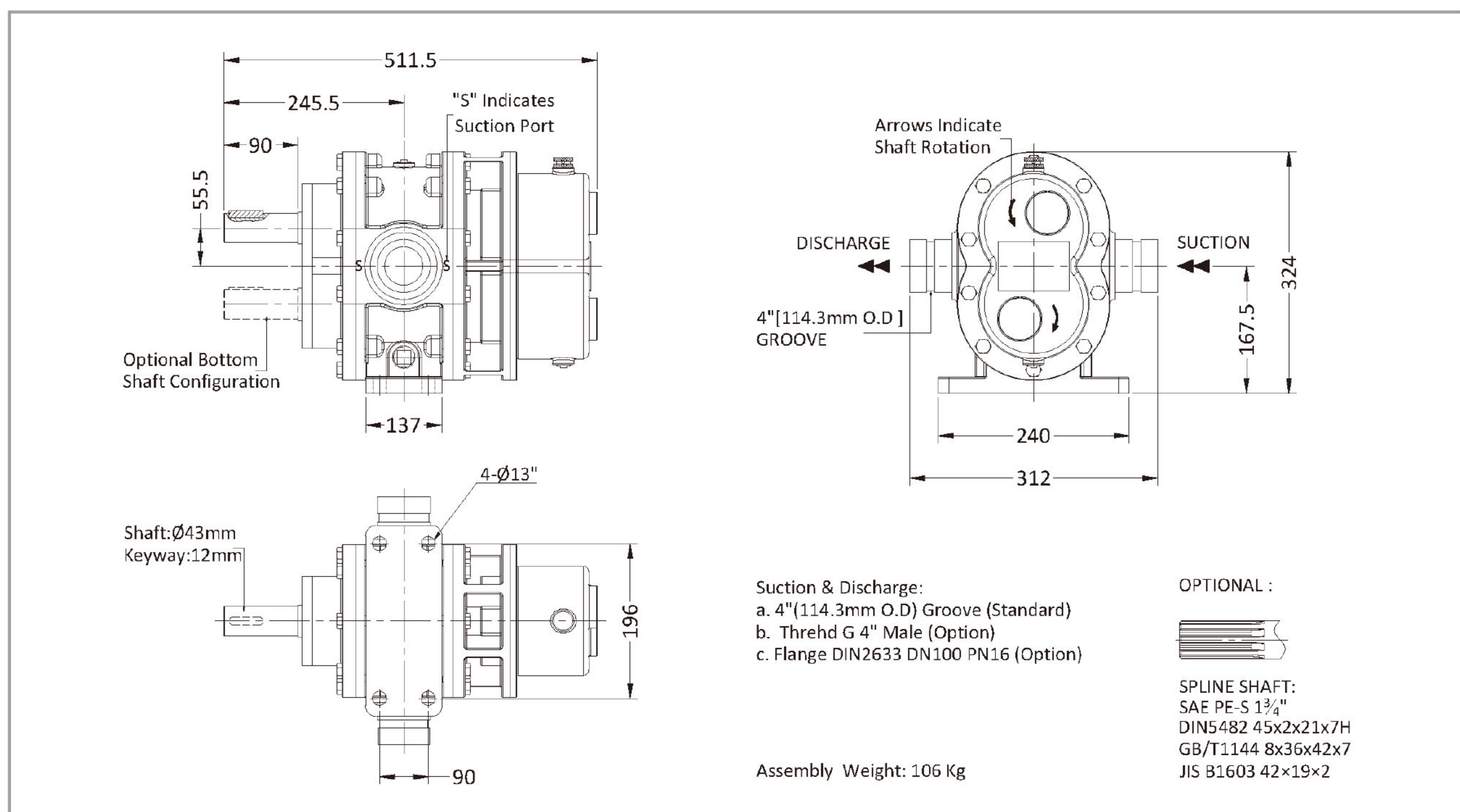

Model G8T-120 Rotary Gear Pump

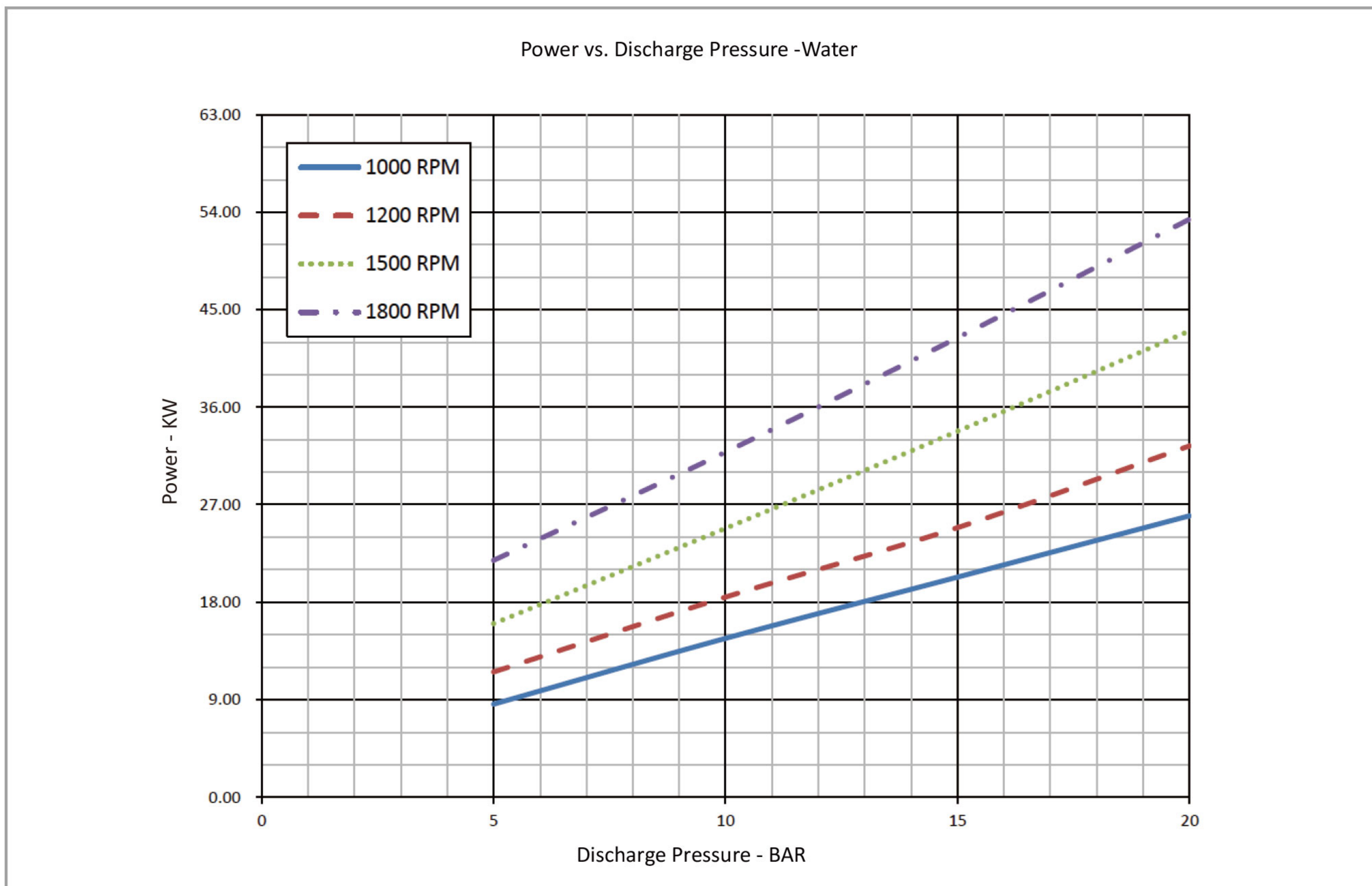
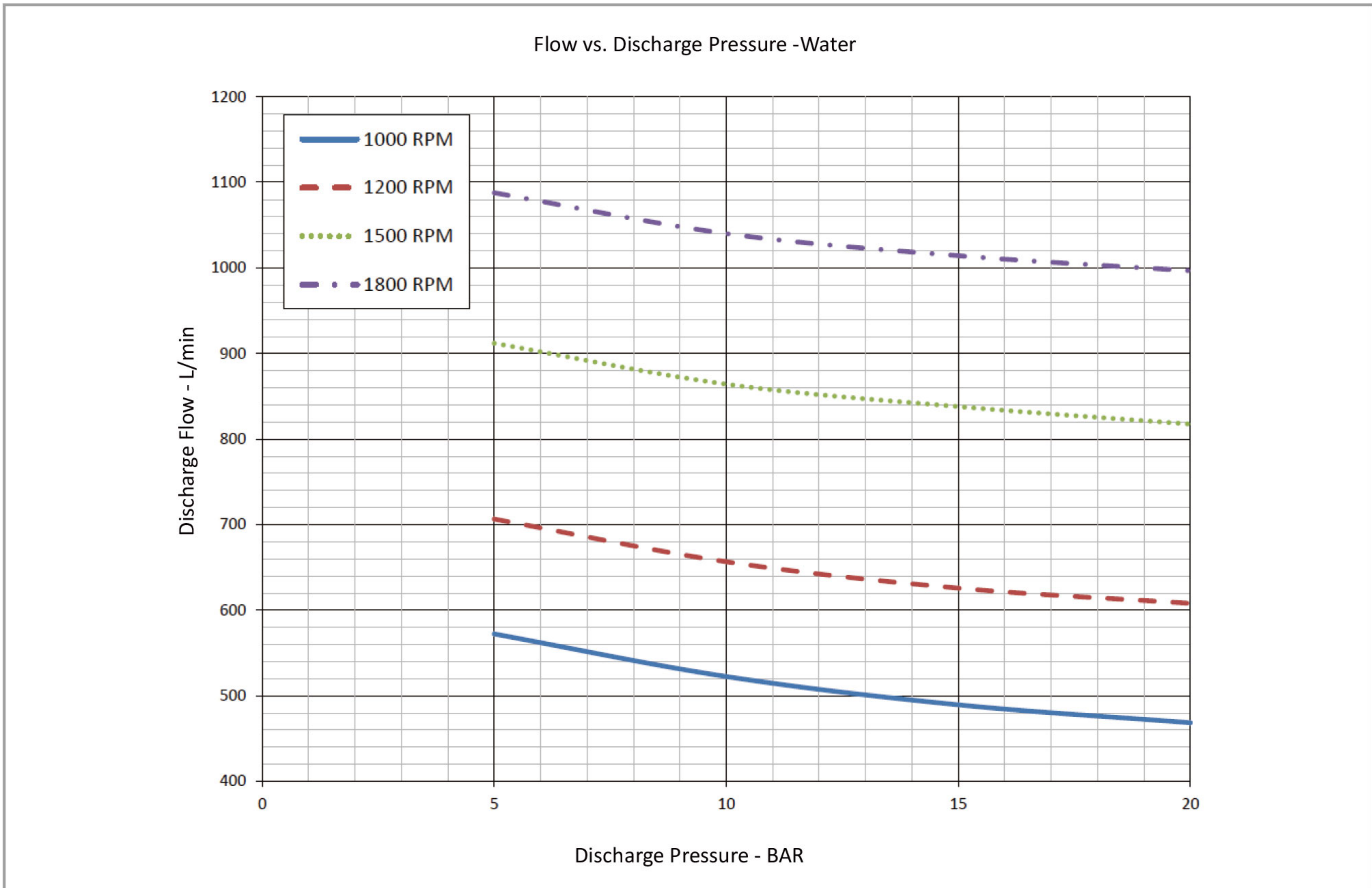

• The pump performance for foam concentrate, please contact Surex, or down load from www.surexfoam.com.